

- 1 CAVITY LOCATION DIMENSIONS INCREASE IN INCREMENTS OF .100 TOLERANCES ARE NON-CUMULATIVE
- 2 USE EXTRACTION TOOL 91052-1 TO REMOVE RECEPTACLE CONTACTS.
- 3 THESE HOUSINGS ARE COMPATIBLE WITH ANY MOD II SHROUDED HEADER
- 4 HOUSING WILL ACCOMMODATE ALL MOD IV, IV.5 AND MOD V CONTACTS.

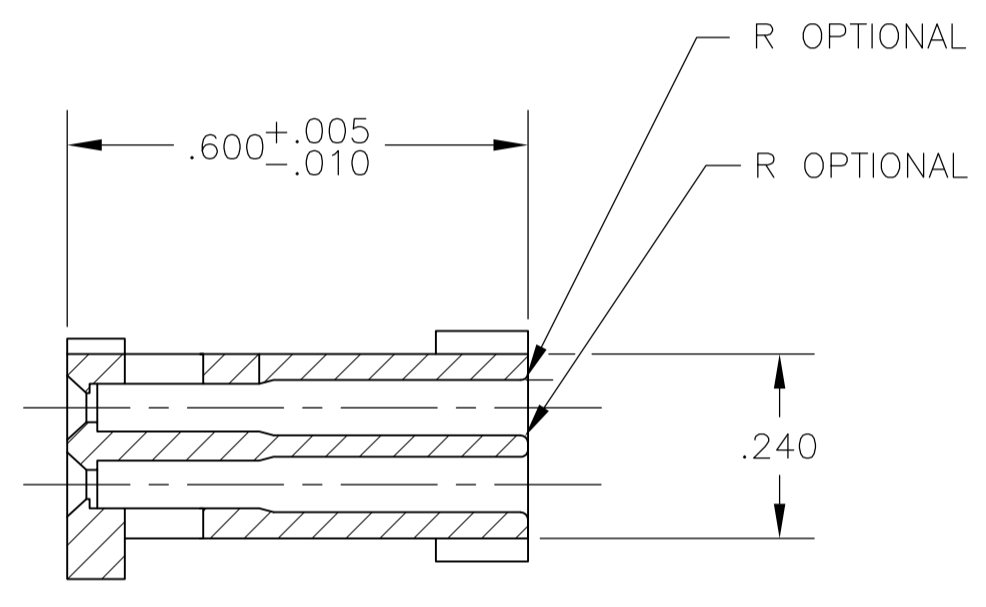

SECTION Y-Y

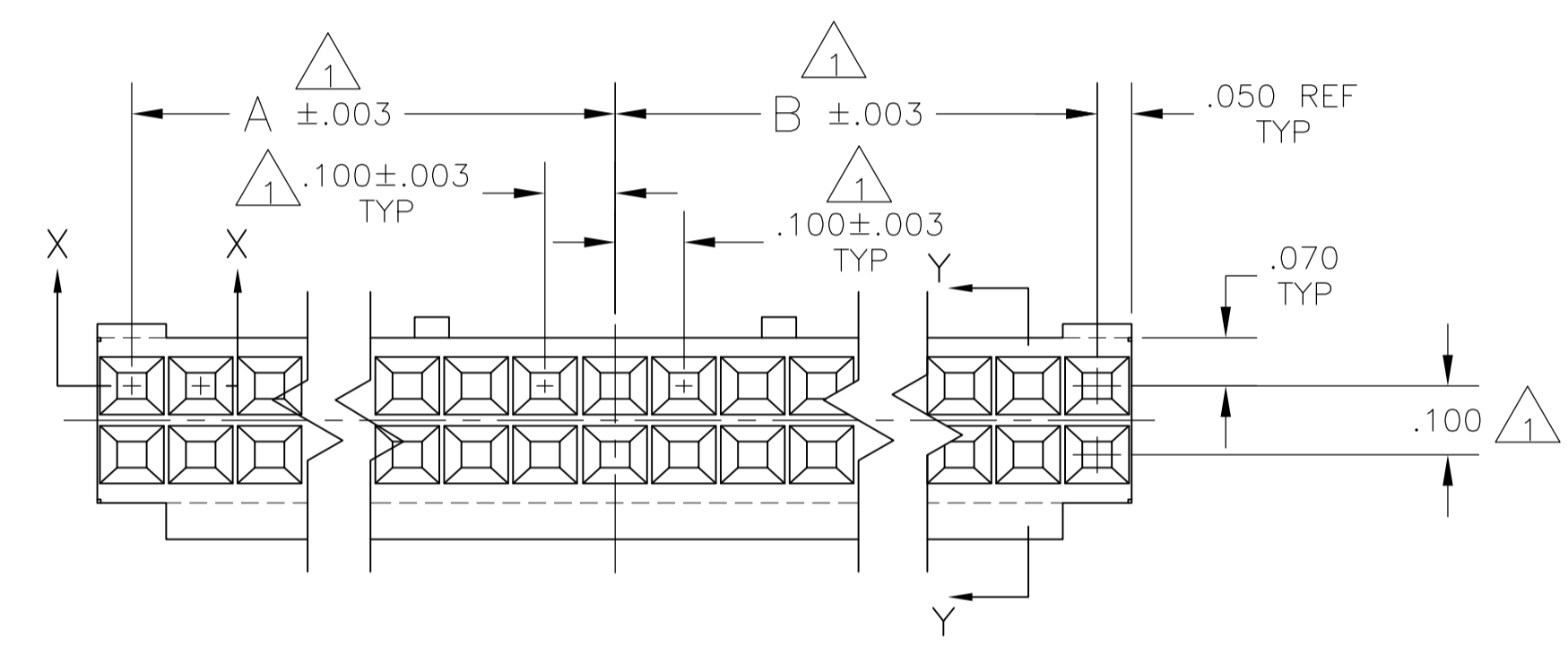
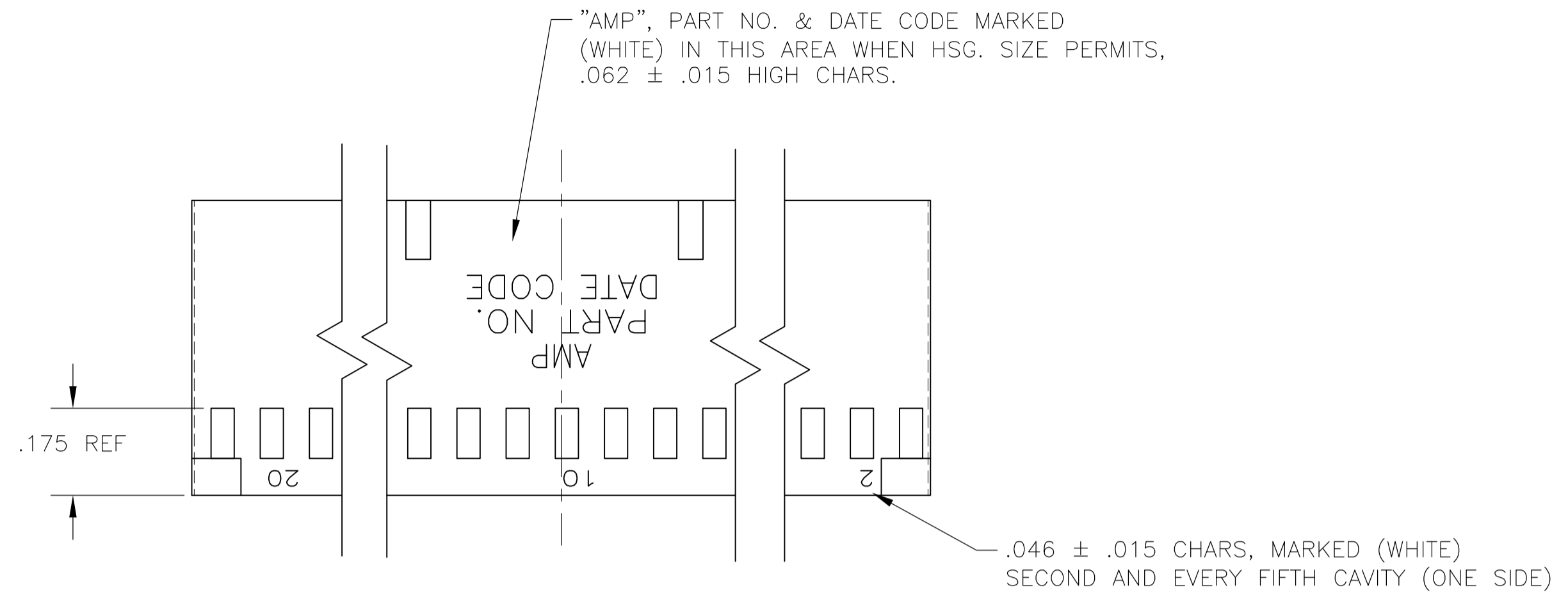
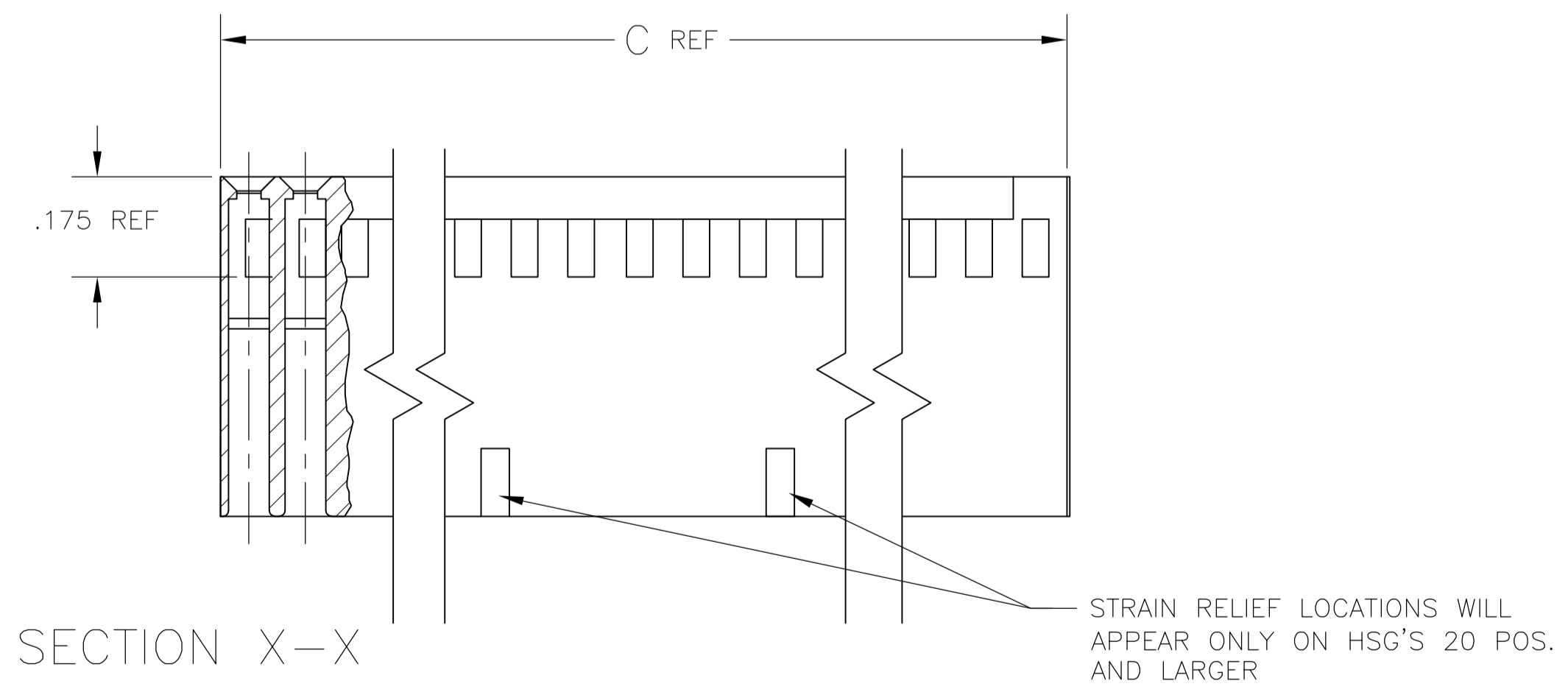

SECTION X-X

3.200	1.500	1.600	64	6-87977-2	6-87977-1
2.900	1.400	1.400	58	6-87977-0	5-87977-9
2.800	1.300	1.400	56	5-87977-8	5-87977-7
2.400	1.100	1.200	48	5-87977-6	5-87977-5
3.600	1.700	1.800	72	5-87977-4	2-87977-7
3.500	1.700	1.700	70	5-87977-3	2-87977-6
3.300	1.600	1.600	66	5-87977-2	2-87977-5
3.000	1.400	1.500	60	5-87977-1	2-87977-4
2.700	1.300	1.300	54	5-87977-0	2-87977-3
2.600	1.200	1.300	52	4-87977-9	2-87977-2
2.500	1.200	1.200	50	4-87977-8	2-87977-1
2.200	1.000	1.100	44	4-87977-7	2-87977-0
2.100	1.000	1.000	42	4-87977-6	1-87977-9
2.000	.900	1.000	40	4-87977-5	1-87977-8
1.900	.900	.900	38	4-87977-4	1-87977-7
1.800	.800	.900	36	4-87977-3	1-87977-6
1.700	.800	.800	34	4-87977-2	1-87977-5
1.600	.700	.800	32	4-87977-1	1-87977-4
1.500	.700	.700	30	4-87977-0	1-87977-3
1.400	.600	.700	28	3-87977-9	1-87977-2
1.300	.600	.600	26	3-87977-8	1-87977-1
1.200	.500	.600	24	3-87977-7	1-87977-0
1.100	.500	.500	22	3-87977-6	87977-9
1.000	.400	.500	20	3-87977-5	87977-8
.900	.400	.400	18	3-87977-4	87977-7
.800	.300	.400	16	3-87977-3	87977-6
.700	.300	.300	14	3-87977-2	87977-5
.600	.200	.300	12	3-87977-1	87977-4
.500	.200	.200	10	3-87977-0	87977-3
.400	.100	.200	8	2-87977-9	87977-2
.300	.100	.100	6	2-87977-8	87977-1
C	B	A	POS	PART NUMBER (UNMARKED)	NUMBER PART (MARKED)

THIS DRAWING IS A CONTROLLED DOCUMENT. BOB BOLES BG 18DEC89  
 CJK 050CT93  
 P-SREMCJCH 050CT93  
 NAME: CONNECTOR HSG., MOD IV, CRIMP SNAP-IN, .100 X .100 CL

TOLERANCES UNLESS OTHERWISE SPECIFIED:  
 0. PLC ± -  
 1. PLC ± -  
 2. PLC ± -  
 3. PLC ± .005  
 4. PLC ± -  
 ANGLES ± -

MATERIAL: FLAME RETARDANT GLASS FILLED NYLON  
 COLOR-BLACK PER ASTM D4066

FINISH: -

WEIGHT: -

SIZE: A1  
 CAGE CODE: 00779  
 DRAWING NO: 87977

CUSTOMER DRAWING

SCALE: 4:1  
 SHEET: 1 OF 1  
 REV: T1